

CI/SIB	(29)	E16	
May 2012 (Version 2)			

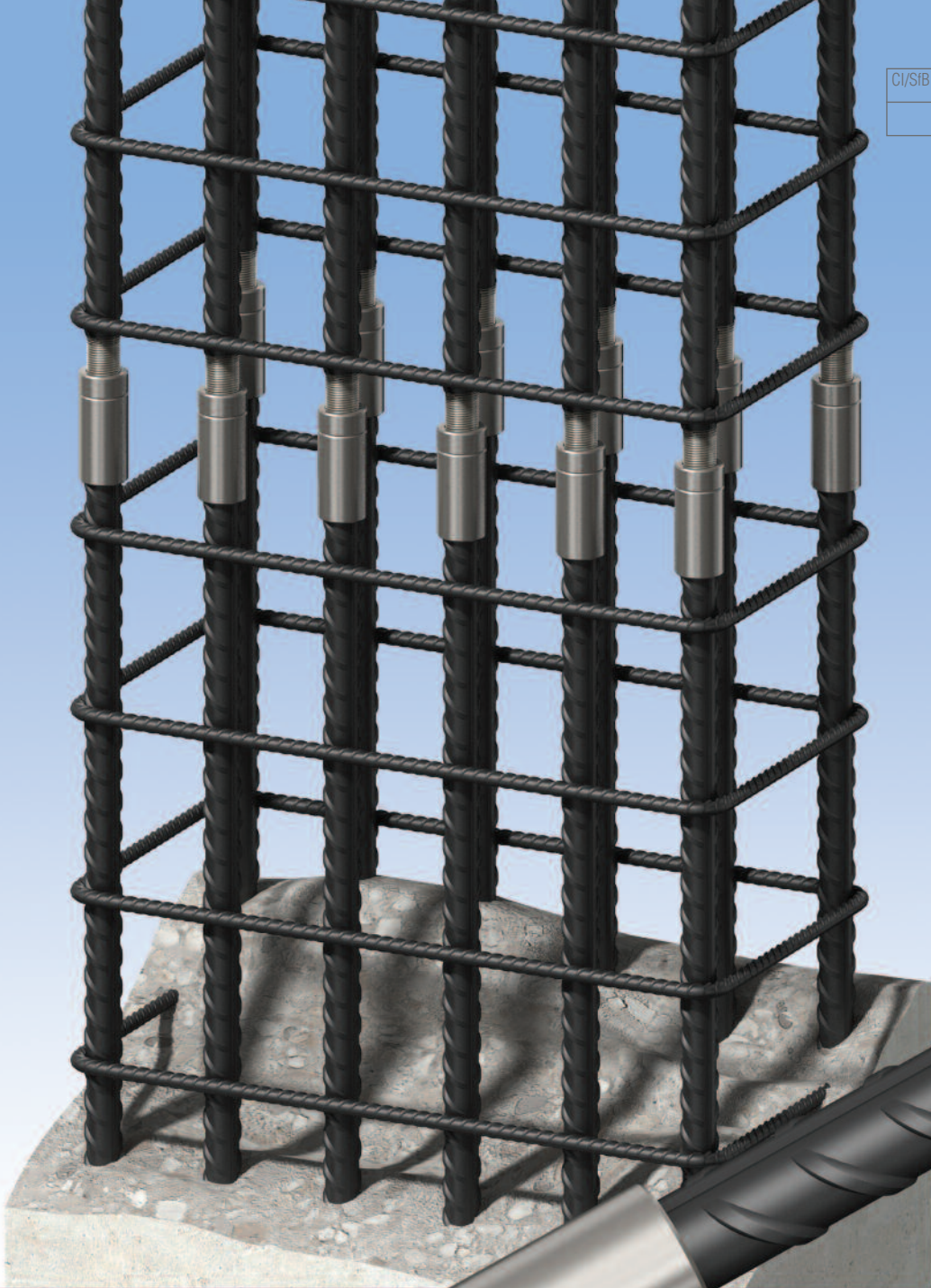

## Reinforcing Bar Couplers

for the Construction Industry

**Ancon**<sup>®</sup>  
BUILDING PRODUCTS



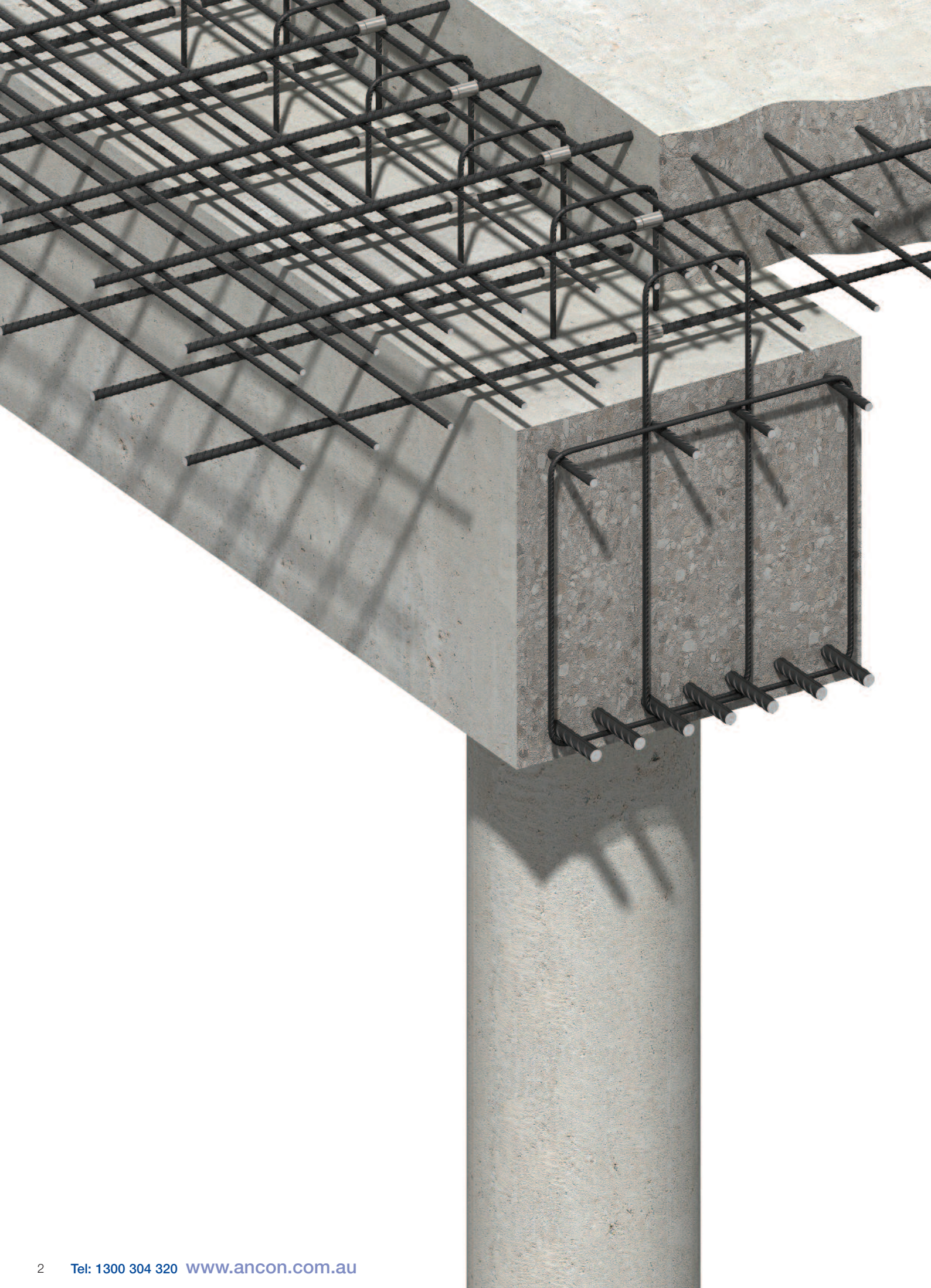





**Ancon designs and manufactures high integrity steel products for the construction industry. Through continuous programmes of new product development, inward investment and employee advancement, the company is committed to maintaining the highest level of customer service within a dynamic and challenging industry.**

For many years the use of mechanical couplers to join reinforcing bars has been regarded as a means of reducing the use of long bars. Engineers and contractors now recognise the benefits of using couplers to accelerate the speed of construction, increase productivity and simplify design details.

Masonry Support Systems	Coupler Selection	4-5
Windposts and Lintels	BT Series	6-8
Wall Ties and Restraint Fixings	Ancon Anchors	9
Channel and Bolt Fixings	MBT ET Series	10-11
Tension and Compression Systems	MBT Transition Series	12-13
Stainless Steel Fabrications	MBT Headed Anchors	14
Flooring and Formed Sections	MBT Electric Wrench	15
Shear Load Connectors	Other Ancon Products	15
Stainless Steel Reinforcement		
<b>Reinforcing Bar Couplers</b>		
Reinforcement Continuity Systems		
Punching Shear Reinforcement		
Precast Concrete Accessories		



# Reinforcing Bar Couplers

## Reinforcing Bar Couplers

Lapped joints are not always an appropriate means of connecting reinforcing bars.

The use of laps can be time consuming in terms of design and installation and can lead to greater congestion within the concrete because of the increased amount of rebar used.

Ancon couplers can simplify the design and construction of reinforced concrete and reduce the amount of reinforcement required.

Lapped joints are dependent upon the concrete for load transfer. For this reason any degradation in the integrity of the concrete could significantly affect the performance of the joint. The strength of a mechanical splice is independent of the concrete in which it is located and will retain its strength despite loss of cover as a result of impact damage or seismic event.

The Ancon range of reinforcing bar couplers is the most comprehensive available and includes parallel threaded and mechanically bolted couplers.

Ancon reinforcing bar couplers are available through major rebar stockists and approved distributors.

## Characteristic Strengths of High Yield Reinforcing Bar

Diameter (mm)	Area (mm <sup>2</sup> )	Fy(kN) 500MPa
10	78.5	39.3
12	113	56.5
16	201	100.5
20	314	157.0
24	452	226.2
28	616	307.9
32	804	402.1
36	1,018	509.0
40	1,256	628.3
50	1,963	981.7

## Coupler Selection

Ancon couplers are designed to exceed the tensile strength for reinforcing bars to AS 3600: 2009 and AS 4671: 2001.

The two types of Ancon reinforcing bar couplers require different fixing methods. This, together with the quantity to be fixed and the location, will determine which is the most appropriate coupler for a particular situation.

## Availability of Couplers

Bar Diameter	10	12	16	20	24	28	32	36	40	50
BT		✓	✓	✓	✓	✓	✓	✓	✓	✓
Ancon Anchor		✓	✓	✓	✓	✓	✓	✓	✓	✓
MBT ET	✓	✓	✓	✓	✓	✓	✓	✓	✓	✓
MBT Transition		✓	✓	✓	✓		✓		✓	
MBT Anchor	✓	✓	✓	✓	✓	✓	✓	✓	✓	✓

## BT Parallel Threaded Couplers

The BT system is one of the smallest and the most cost-effective coupler systems in our range, when used on large scale, high coupler volume projects. The ends of the bars are enlarged and a parallel thread is cut onto the ends to suit the threaded coupler. The coupler is assembled using a pipe or chain wrench. Calibrated wrenches are not necessary.

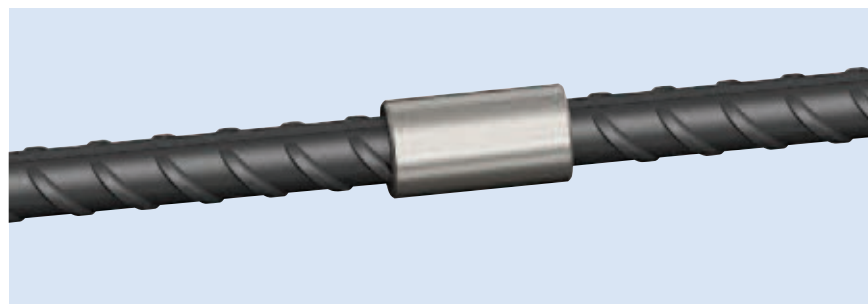

## MBT Mechanically Bolted Couplers

MBT couplers are suitable where it is not convenient to have the bar ends prepared for the BT system. The bars are supported within the coupler on two serrated saddles. Bars are locked in place by a series of special lockshear bolts, the heads of which shear off when the predetermined tightening torque is reached, providing a visual check of correct installation.

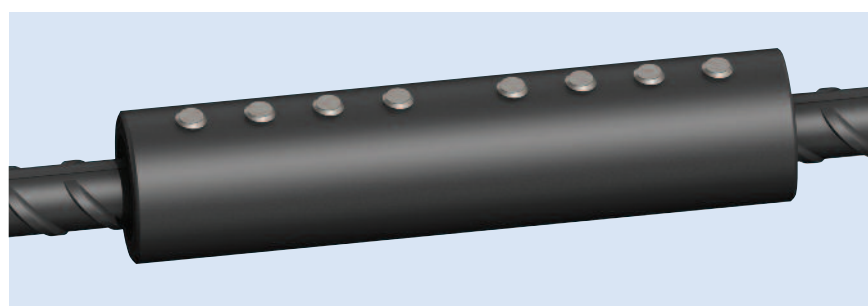

## Coupler Range

Range	BT			Ancon Anchor	MBT		
Type	Type A	Type B	Type C	BTAA	ET	Transition	HA
Bar Dia. (mm)	12-50	12-50	12-50	12-50	10-50	10-40	10-40
Bar End Prep	Threaded	Threaded	Threaded	Threaded	No	No	No
Bar Rotation Required	Yes	Limited	No	N/A	No	No	No
Installation Method	Wrench			Wrench	Wrench or Nut Runner		
Minimum Tensile Capacity	Full Strength up to 650MPa			Full Strength up to 650MPa	Full Strength up to 575MPa		

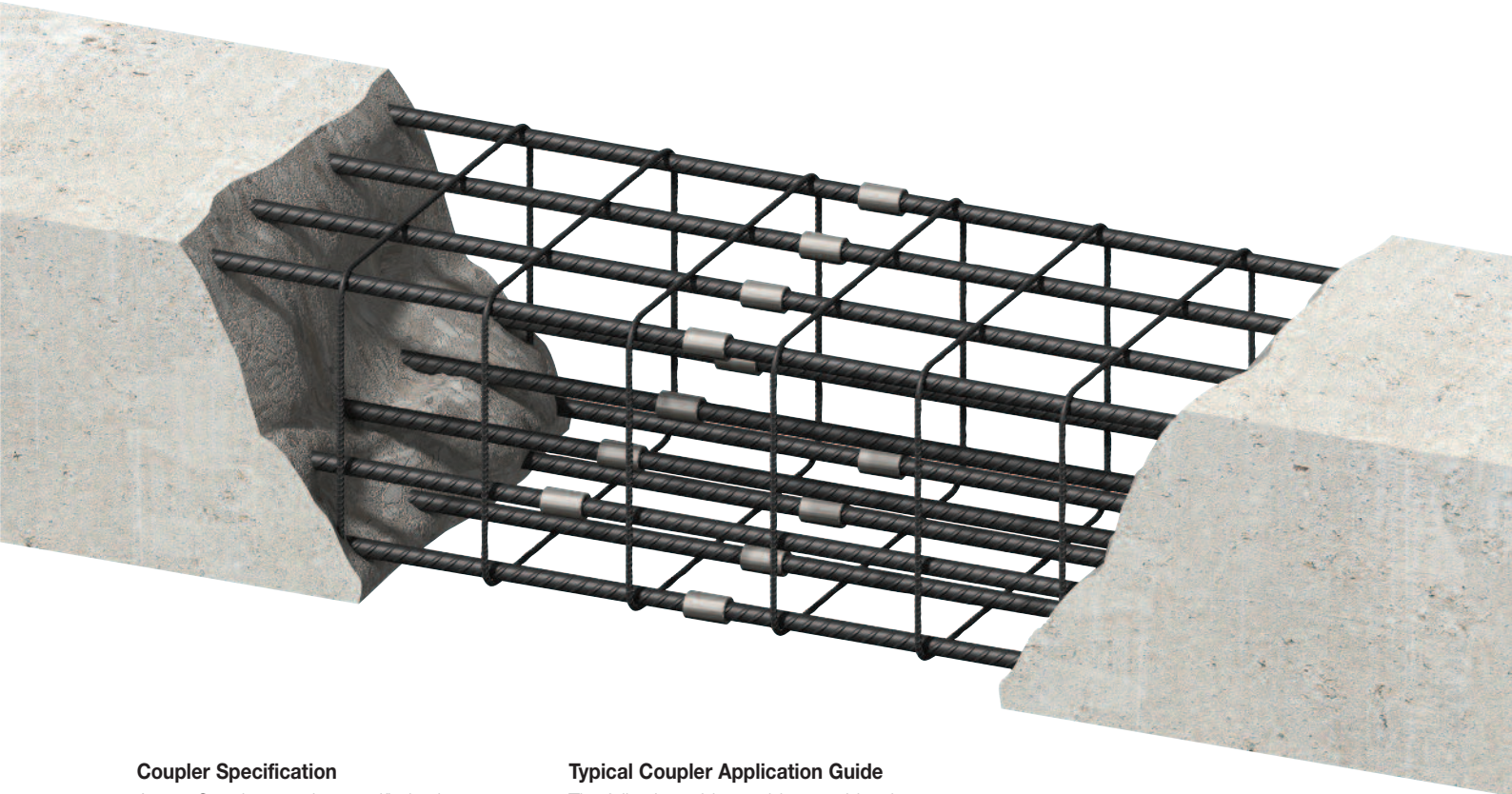

### Coupler Specification

Ancon Couplers can be specified using the part numbers which are included in the tabulated data in each section of this brochure.

The following examples show how each type of coupler should be specified when using 20mm bar.

Type of Coupler	Reference
BT Type A	<b>BT20/A</b>
BT Type B	<b>BT20/B</b>
BT Type C	<b>BT20/C</b>
Ancon Anchor	<b>BTAA20</b>
MBT ET Series	<b>ET20</b>
MBT Transition Series	<b>ET20/16</b>
MBT ET Headed Anchor	<b>ETHA20</b>

CAD drawings of Ancon couplers are available to download from [www.ancon.com.au](http://www.ancon.com.au)

### Typical Coupler Application Guide

The following table provides a guide when selecting the most appropriate coupler for specific applications. Recommendations are based upon typical usage. For further assistance with coupler suitability and specification, please contact Ancon Building Products.

Application	BT	MBT
Wall to slab connection	✓	
Wall to pre-cast beam connection	✓	
Column construction	✓	✓
Extension / repairs to existing structures		✓
Pre-cast element to pre-cast element connection	✓	✓
Closing of access openings	✓	✓
Rebar cage pre-fabrication	✓	✓
Hook bars to pile connection		✓
Fatigue applications	✓	✓
Bar end terminations	✓	✓

# Reinforcing Bar Couplers

## BT Parallel Threaded Couplers

BT couplers produce a full strength joint yet they are among the smallest in the Ancon range, best suited to large scale projects requiring a high volume of couplers.

The end of each bar to be joined is cut square and enlarged by cold forging. This increases the core diameter of the bar to ensure that the joint is stronger than the bar.



Parallel metric threads are cut onto the enlarged ends. The threaded end can be proof tested to a force equal to the characteristic yield strength of the bar. A nominal allowance of +50mm per threaded bar end should be made for cutting square and cold forging.

The threaded ends of the bars are protected by an external plastic sheath. Couplers, which are usually supplied attached to the bar, have their internal threads protected by an internal plastic end cap. For certain applications, especially where the BT system is being used in deep pours, the coupler end caps may not prevent the ingress of concrete fines. For these applications, further protection may be required.

BT couplers are also available to join bars of different diameters. For further information please contact Ancon Building Products.

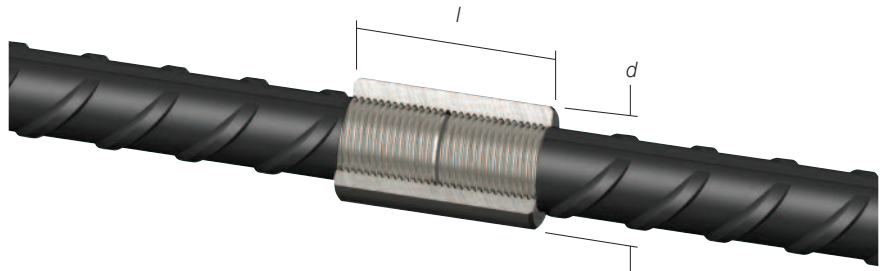

### Dimensions

Bar Diameter		12	16	20	24	28	32	36	40	50
External Dia.	$d$	22	30	35	42	48	55	60	65	80
Coupler Length	$l$	28	40	48	60	66	72	84	90	112
Thread Size		M14	M20	M24	M30	M33	M36	M42	M45	M56
Thread Pitch		2.0	2.5	3.0	3.5	3.5	4.0	4.5	4.5	5.5
Weight (kg)		0.05	0.14	0.20	0.36	0.55	0.84	1.06	1.35	2.49
Part No Type A		BT12/A	BT16/A	BT20/A	BT24/A	BT28/A	BT32/A	BT36/A	BT40/A	BT50/A
Part No Type B		BT12/B	BT16/B	BT20/B	BT24/B	BT28/B	BT32/B	BT36/B	BT40/B	BT50/B
Part No Type C		N/A	BT16/C	BT20/C	BT24/C	BT28/C	BT32/C	BT36/C	BT40/C	BT50/C

**Note:** All dimensions are approximate and subject to change without notice.

### BT Type A

The BT Type A system utilises internally threaded couplers with a single right hand thread and is suitable for applications where the continuation bar can be rotated. The ends of the bars are upset and threaded for half the length of the coupler.

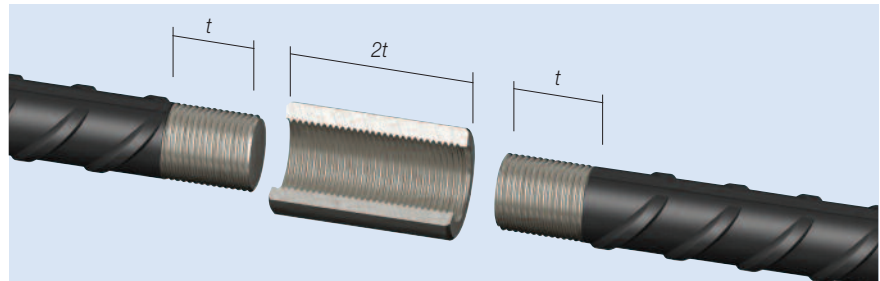

### BT Type B

The BT Type B uses the same coupler as the Type A system, but one bar is threaded for a full coupler length. It is used for applications where it is difficult but not impossible to rotate the continuation bar.

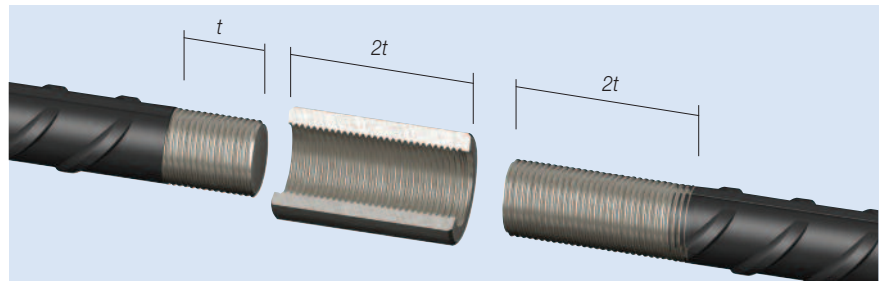

### BT Type C

The BT Type C system has an additional locknut and is used where the continuation bar cannot be rotated. The continuation bar is threaded for the full coupler length plus the length of the locknut.

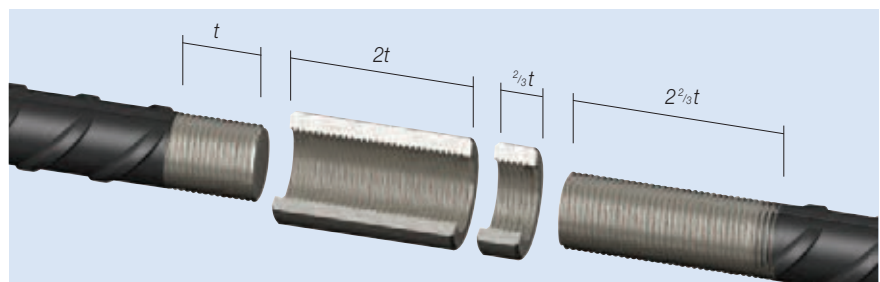



### Two Stage Construction

In two stage construction utilising Types B and C couplers, it is essential to form a pocket in the face of the first stage concrete. This will create the space for the coupler to run onto the thread of the fixed reinforcing bar.

A pocket former can be screwed onto the end of the bar and cast flush with the face of the concrete.

### Mobile Bar End Preparation Facility

BT threading equipment is located within Ancon's premises. Ancon liaises with rebar suppliers to achieve scheduled, on-time deliveries. Couplers are usually supplied pre-fixed to the threaded bar ends.

On large contracts where bar end preparation can be carried out on site, equipment can be made available for hire. It should be noted that the hirer will need to provide sufficient power, air, rebar support tressles and crane handling facilities.



### Testing & Approvals

BT couplers are designed and manufactured in accordance with ISO 9001 and comply in all respects to AS 3600 when used with reinforcing bar to AS 4671. Full destructive tests have been carried out to show compliance with the following codes: ACI 349; ASME III DIV 2 (ACI 359); ACI 318; CSA CAN 3 - N2872.

**BT Couplers of size range 12 - 40mm are approved for use on RMS (formerly RTA) contracts.**

### Typical Test Results

Nominal Bar Size Dia. mm	Yield Stress (MPa)	Ultimate Stress (MPa)	Elongation %	Failure Mode
16	531	587	18	Bar Break
20	518	596	20	Bar Break
24	522	625	18	Bar Break
32	484	604	20	Bar Break
40	512	629	18	Bar Break
50	510	669	17	Bar Break



# Reinforcing Bar Couplers

## Installation

### The BT Type A System

**1**  
Screw the coupler to the rear of the thread on the fixed bar and lock tight. The bar end should be central within the coupler.

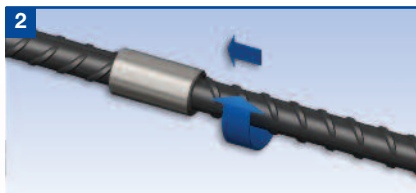
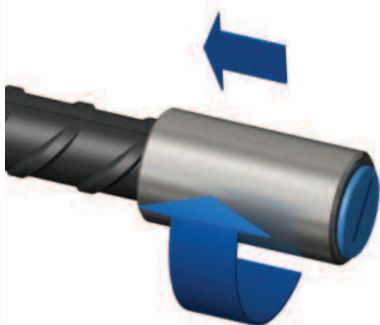

**2**  
Remove the plastic cap from the coupler. Position and rotate the continuation bar in the coupler.

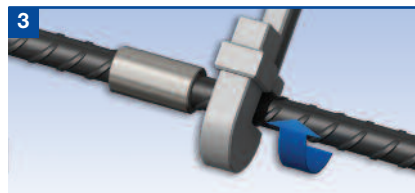

**3**  
Tighten the joint using a wrench on the continuation bar. After tightening there should be no more than 2-4mm of thread exposed, depending on the diameter of the rebar.

### The BT Type B System

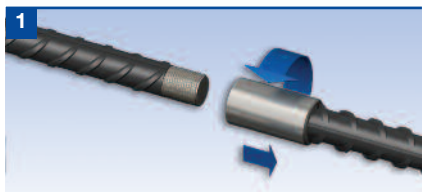

**1**  
Screw the coupler to the rear of the thread on the continuation bar.

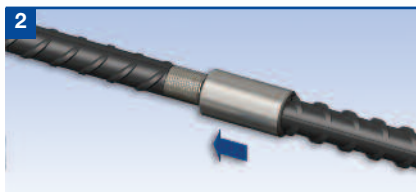

**2**  
Position the continuation bar with the coupler against the end of the first bar.



**3**  
Rotate the coupler from the continuation bar to engage against the rear of the thread on the opposing bar and lock tight.

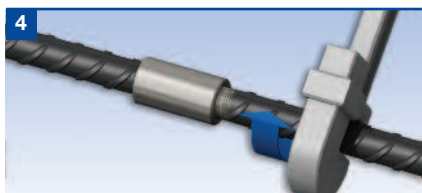

**4**  
Using a wrench, rotate the continuation bar to lock the two bar ends against each other within the coupler. After tightening, the length of exposed thread should be no more than half of the coupler length plus 2-4mm depending on the diameter of the rebar.

### The BT Type C System

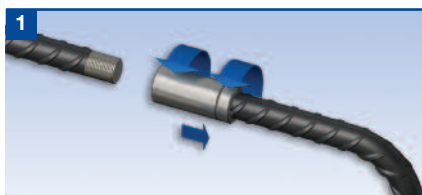

**1**  
Screw the locknut followed by the coupler to the rear of the thread on the continuation bar.



**2**  
Position the continuation bar with the coupler against the end of the first bar.

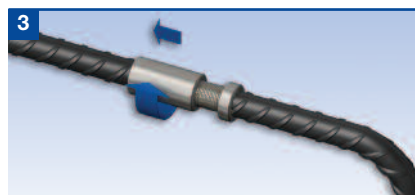

**3**  
Rotate the coupler from the continuation bar to engage against the rear of the thread on the opposing bar and lock tight.

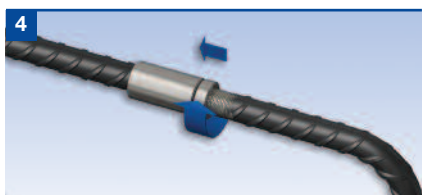

**4**  
Rotate the locknut along the continuation bar to abut the coupler.



**5**  
Hold the rebar in its required orientation and with a wrench tighten the locknut against the coupler.



## Ancon Anchors

Ancon Anchors create an anchorage in the concrete, replacing the need for cogged or hooked bar ends. They can simplify scheduling and bar placement, and reduce congestion in the concrete.

Designed for use on 12mm to 50mm reinforcing bars, Ancon Anchors are internally threaded with metric threads to suit the BT coupler system. They create a full strength joint, the mode of failure being bar break.



Ancon Anchors are fully compliant with AS 3600: 2009 that states that providing the anchor's cross sectional area is at least ten times the cross sectional area of the bar, the development length is 0.4 times that of a straight bar.

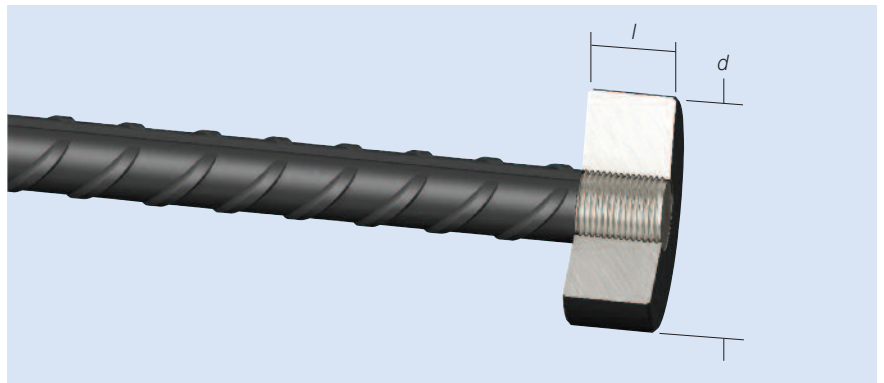

Bar Diameter		12	16	20	24	28	32	36	40
Anchor Length	$l$	16	20	24	30	33	36	42	45
External Dia.	$d$	38	50	64	76	89	102	114	127
Thread Size		M16 x 2.0	M20 x 2.5	M24 x 3.0	M30 x 3.5	M33 x 3.5	M36 x 4.0	M42 x 4.5	M45 x 4.5
Part No.		BTAA12	BTAA16	BTAA20	BTAA24	BTAA28	BTAA32	BTAA36	BTAA40

**Note:** BTAA50 couplers can be manufactured, for details contact Ancon Building Products.

# Reinforcing Bar Couplers

## MBT Mechanically Bolted Couplers

The MBT range of couplers provides a cost-effective method of joining reinforcing bars, particularly when the fixed bar is already in place and there is insufficient space for a hydraulic swaging press. They are easy to install and achieve failure loads higher than 110% of the characteristic yield strength of grade 500 reinforcing bar. Neither bar end preparation to form threads, nor bar rotation are required. MBT couplers can also be used to join imperial, plain round or deformed reinforcing bars.

The bar ends are supported within the coupler by two serrated saddles, and as the lockshear bolts are tightened, the conical ends embed themselves into the bar. As this happens the serrated saddles bite into both the bar and the shell of the coupler. The lockshear bolts of couplers up to and including the ET20 can be tightened using a ratchet wrench. For larger couplers a nut runner is recommended.

In all cases heavy duty sockets should be used. When the pre-determined tightening torque for the bolts is reached, the heads shear off leaving the top of the installed bolt slightly proud of the coupler. This provides an instant visual check of correct installation.

**Note:** Impact tools must not be used to tighten lockshear bolts.

## MBT ET Series

The MBT ET series of couplers is used to connect reinforcing bars of the same size.

## Testing & Approvals

Full destructive tests are carried out on selected



couplers from our stocks. MBT couplers are designed and manufactured in accordance with BS EN ISO 9001. The most common sizes of ET series couplers are approved by the BBA and are covered by the Roads and Bridges Agrément Certificate No. 98/R102. Sizes ET10 - ET28 have been tested and approved by the DIBt and are covered by Approval No Z-1.5-10. In addition the coupler has been tested to show compliance with the following international design codes:- BS5400, BS8110, ACI 318, DIN 1045 German code and RMS (formerly RTA) specifications.

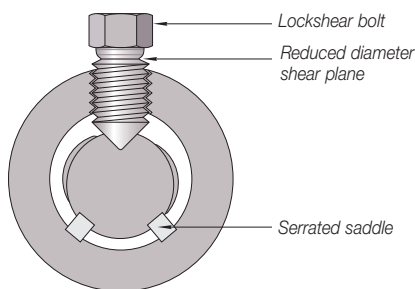

Section showing the embedment of the lockshear bolts and saddles into the bar and the shell of the coupler.

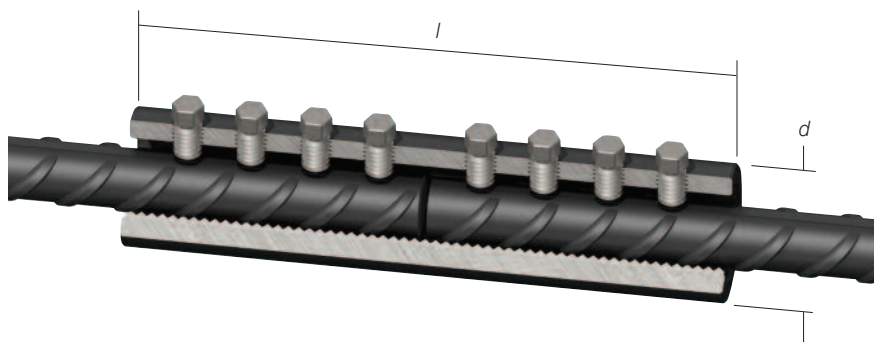

## MBT ET Series Dimensions

Bar Diameter		10	12	16	20	24	28	32	36	40
External Diameter	$d$	33.4	33.4	42.2	48.3	54.0	66.7	71.0	75.0	81.0
Total Length	$l$	100	140	160	204	258	312	312	420	484
Socket Size A/F (ins)		$1/2$	$1/2$	$1/2$	$1/2$	$5/8$	$5/8$	$5/8$	$3/4$	$3/4$
No. of Bolts		4	6	6	8	8	10	10	12	14
Approx Weight (kg)		0.52	0.72	1.25	1.96	3.00	5.80	6.50	8.59	11.30
Part No		ET10	ET12	ET16	ET20	ET24	ET28	ET32	ET36	ET40

**Note:** MBT ET50 couplers can be manufactured. For details contact Ancon Building Products.



## Installation

### MBT ET Series

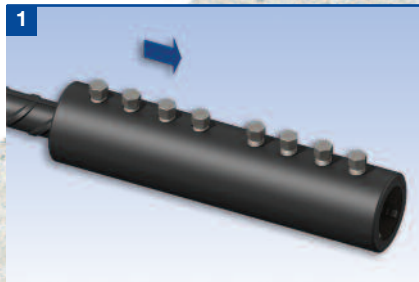

1 Place the coupler over the end of the bar to half the coupler length +/- 6mm and finger tighten the lockshear bolts onto the bar. Check the alignment and make any necessary adjustments.

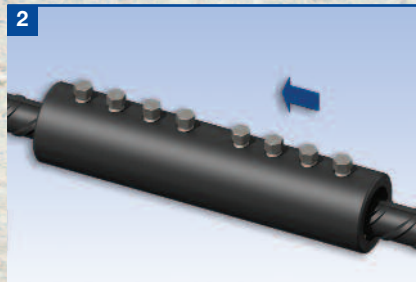

2 Place the other bar end into the coupler until it pushes up against the first bar and finger tighten the remaining lockshear bolts. Check alignment and make any adjustments.

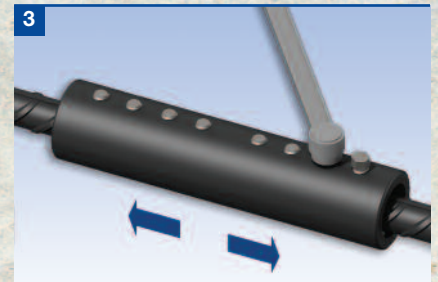

3 On one half of the coupler, starting from the centre and working outwards, partly tighten the lockshear bolts using either a ratchet wrench or a nut runner as appropriate. Do not use impact tools. Repeat again, this time fully tightening the lockshear bolts until the bolt heads shear off.

Repeat the above for the other half of the coupler.





# Reinforcing Bar Couplers



## Repair and Remedial Work

For applications involving replacement of corroded or damaged bars, the replacement bar is cut approximately 5mm shorter to allow clearance for insertion between the sound ends of the original bars. MBT couplers are pushed fully over both ends of the replacement bar and temporarily held in position.

The replacement bar is then correctly positioned and the couplers moved to a previously marked position on the existing bars indicating half the length of the coupler. The lockshear bolts are tightened to complete the installation.

## MBT Transition Series

The MBT Transition series of couplers provides an effective solution for connecting bars of different diameters. Transition couplers have all the benefits of the ET series and are designed to achieve failure loads higher than 110% of the characteristic yield strength of grade 500 reinforcing bar.

They can be installed without any preparation to the bar ends and without any need to rotate bars. The coupler can be rotated to allow access to the bolts for tightening with either a ratchet wrench or a nut runner. In all cases heavy duty sockets should be used. Transition couplers are non-standard and are made to order.

**Note:** Impact tools should not be used to tighten lockshear bolts.

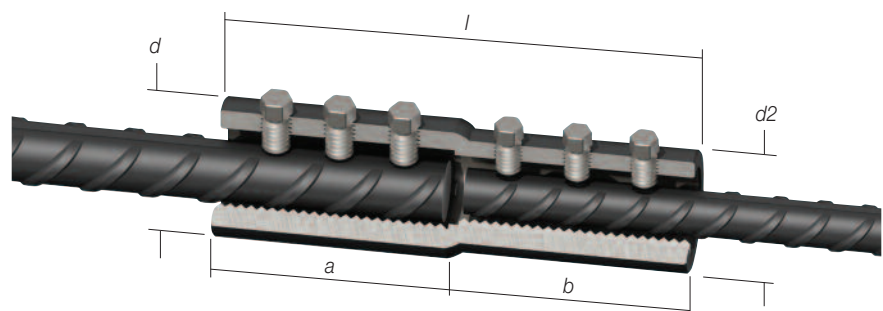

## MBT Transition Series Dimensions

Bar Diameter		20/12	20/16	24/16	24/20	32/20	32/24	40/32
External Diameter	$d$	48.3	48.3	54	54	71	71	81
External Diameter	$d2$	33.4	48.3	42.2	54	48.3	54	71
Total Length	$l$	150	160	155	180	177	231	335
Individual Lengths	$a:b$	80:70	80:80	75:80	90:90	75:102	102:129	178:157
Socket Size A/F (ins)	$a:b$	$1/2:1/2$	$1/2:1/2$	$5/8:1/2$	$5/8:1/2$	$5/8:1/2$	$5/8:5/8$	$3/4:5/8$
No. of Bolts	$a:b$	3:3	3:3	2:3	3:3	2:4	3:4	5:5
Approx Weight (kg)		1.13	1.56	1.51	2.23	2.55	3.70	7.47
Part No		ET20/12	ET20/16	ET24/16	ET24/20	ET32/20	ET32/24	ET40/32





## Installation

### MBT Transition Series

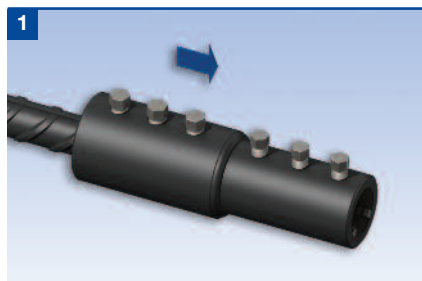

Place the coupler over the end of the bar to the appropriate depth  $\pm 6$ mm and finger tighten the lockshear bolts onto the bar. Check the alignment and make any necessary adjustments.

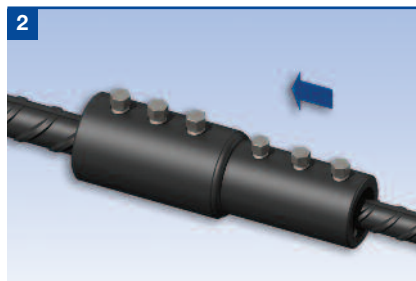

Place the other bar end into the coupler until it pushes up against the first bar and finger tighten the remaining lockshear bolts. Check alignment and make any adjustments.

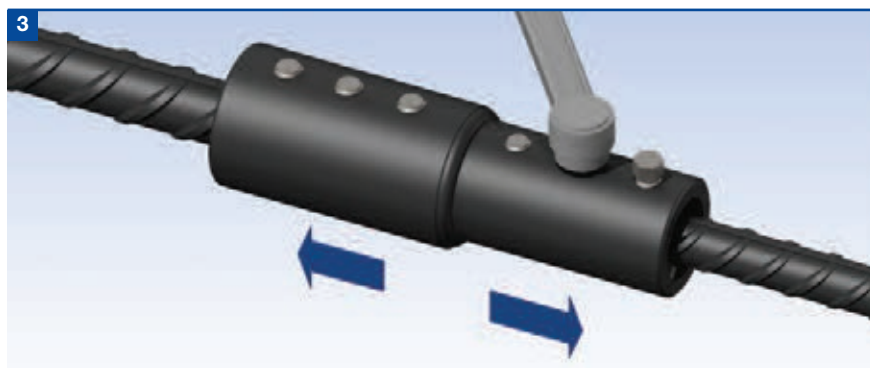

On one half of the coupler, starting from the centre and working outwards, partly tighten the lockshear bolts using either a ratchet wrench or a nut runner as appropriate. Do not use impact tools. Repeat again, this time fully tightening the lockshear bolts until the bolt heads shear off. Repeat the above for the other half of the coupler



# Reinforcing Bar Couplers

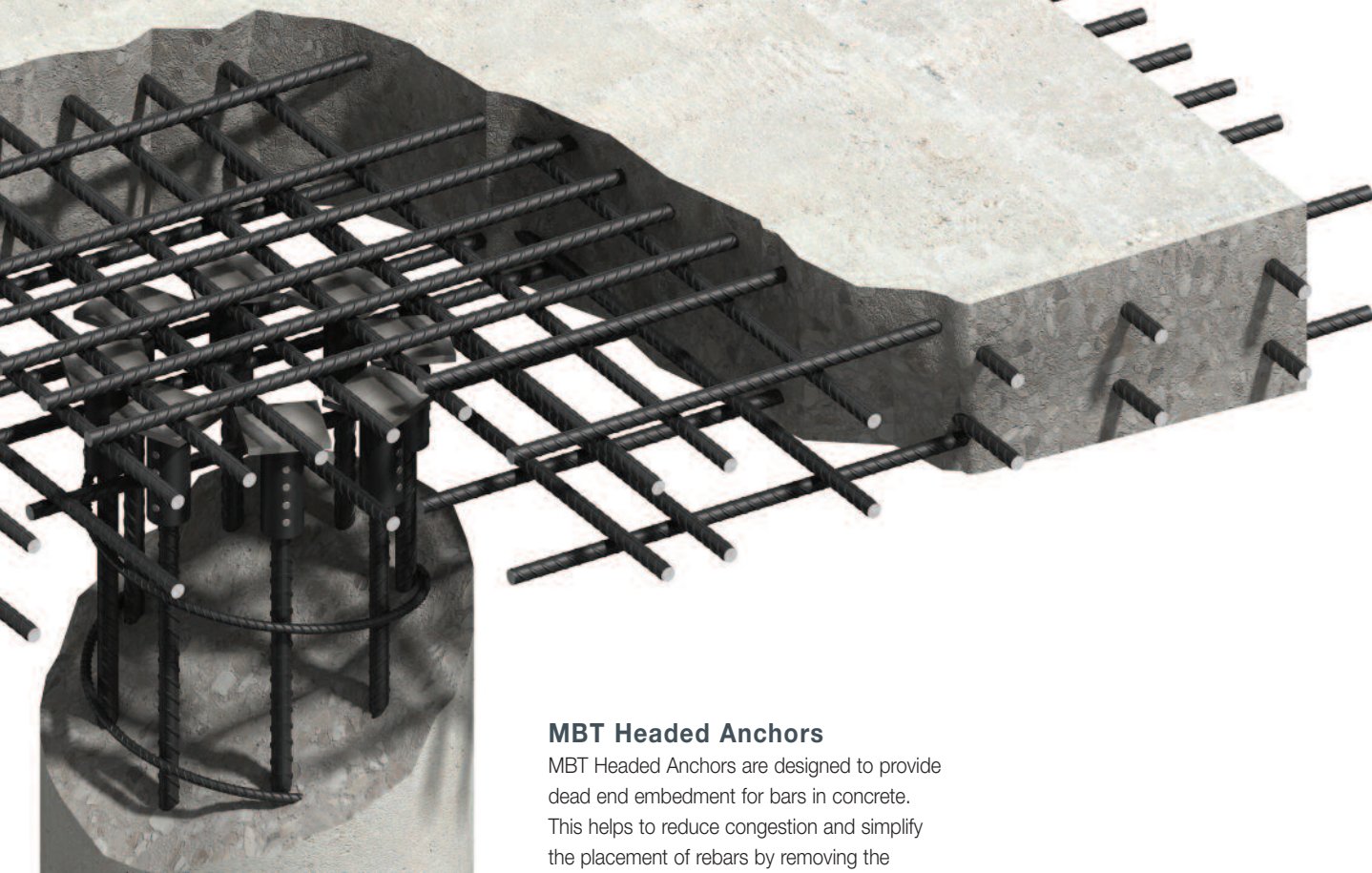

## MBT Headed Anchors

MBT Headed Anchors are designed to provide dead end embedment for bars in concrete. This helps to reduce congestion and simplify the placement of rebars by removing the need for hooked ends. The anchor comprises half an MBT coupler with a plate welded to one end which carries the full tension load of the bar when it is bearing against the concrete. The MBT Headed Anchor also has the added advantage of requiring no special bar end preparation.

MBT Headed Anchors are made to order.

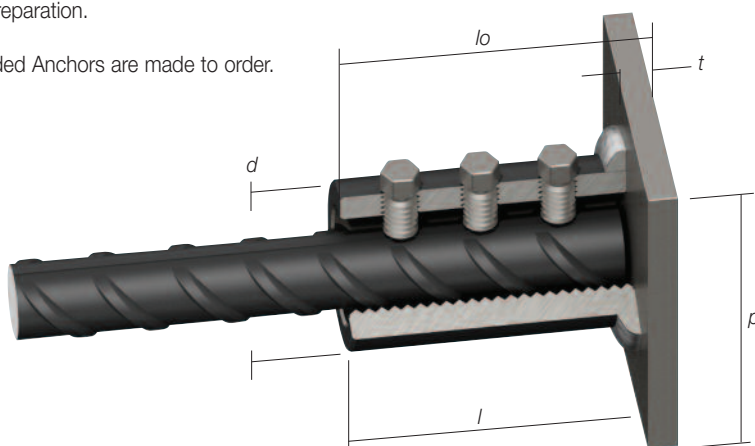

Bar Diameter		10	12	14	16	20	24	28	32	36	40
External Diameter	$d$	33.4	33.4	42.2	42.2	48.3	54.0	66.7	71.0	75.0	81.0
Coupler Length	$l$	55	75	82	82	104	129	156	156	215	247
Total Length	$l_o$	65	85	92	92	114	139	168	171	230	262
Plate Thickness	$t$	10	10	10	10	10	10	12	15	15	15
Plate w x h	$p$	70	70	70	80	90	100	110	130	150	150
Socket Size A/F (ins)		1/2	1/2	1/2	1/2	1/2	5/8	5/8	5/8	3/4	3/4
No of Bolts		2	3	3	3	4	4	5	5	6	7
Approx Weight (kg)		0.64	0.74	1.01	1.07	1.58	2.29	4.14	4.72	5.83	8.30
Part No.		ETHA10	ETHA12	ETHA14	ETHA16	ETHA20	ETHA24	ETHA28	ETHA32	ETHA36	ETHA40

Note: Minimum compressive strength of concrete 25MPa.





## Other Ancon Products

### Reinforcement Continuity Systems

Reinforcement Continuity Systems are an increasingly popular means of maintaining continuity of reinforcement at construction joints in concrete. The Ancon Keybox system eliminates the need to drill shuttering and can simplify formwork design, thereby accelerating the construction process. It is available in both standard units and special configurations. Ancon KSN threaded anchors eliminate the need for on-site bar straightening and are available for use with 12mm, 16mm and 20mm diameter reinforcement. The system is also available with a re-useable rebate former.



### Electric Wrench

To facilitate the installation of MBT couplers Ancon Electric Wrenches are available for purchase or hire. The smooth continuous action of the wrench prevents the early shearing of the lockshear bolts and damage to threads. The wrench is supplied with specially hardened heavy duty sockets. Please contact Ancon for details.

### Shear Load Connectors

Ancon DSD and ESD Shear Load Connectors are used to transfer shear across expansion and contraction joints in concrete. They are more effective at transferring load and allowing movement to take place than standard dowels, and can be used to eliminate double columns at structural movement joints in buildings. A 'Lockable' dowel is also available for temporary movement joints in post-tensioned concrete frames.

### Punching Shear Reinforcement

Ancon Shearfix is used within a slab to provide additional reinforcement from punching shear around columns. The system consists of double-headed steel studs welded to flat rails and is designed to suit the load conditions and slab depth at each column using free calculation software from Ancon.

### Masonry Support Systems

Masonry cladding on concrete or steel frames is normally supported from stainless steel support systems. Ancon MDC Systems create a continuous angle to support the outer leaf of masonry. Ancon Individual Brackets support masonry features such as curves and arches.

### Channel and Bolt Fixings

Ancon offers a wide range of channels and bolts in order to fix stainless steel masonry support, restraints and windposts to structural frames. Cast-in channels and expansion bolts are used for fixing to the edges of concrete floors and beams. A range of stainless steel set screws and self-drill self-tap screws are designed to fix to steel frames.

### Special Fabrications

Ancon is an ASSDA accredited specialist fabricator and has a wealth of experience in working with a variety of material grades. High integrity steel components are supplied to a wide range of industries including Civil Engineering, Building, Infrastructure, Water Treatment, Nuclear and Mining.



**Note:** Impact tools should not be used to tighten lockshear bolts. In all cases heavy duty sockets should be used.

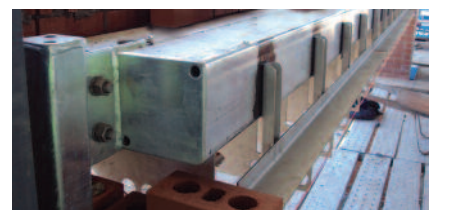

© Thiess, Energy Australia

Masonry Support Systems  
Windposts and Lintels  
Wall Ties and Restraint Fixings  
Channel and Bolt Fixings  
Tension and Compression Systems  
Stainless Steel Fabrications  
Flooring and Formed Sections  
Shear Load Connectors  
Stainless Steel Reinforcement  
**Reinforcing Bar Couplers**  
Reinforcement Continuity Systems  
Punching Shear Reinforcement  
Precast Concrete Accessories



**AUSTRALIAN**

**Ancon Building Products**  
98 Kurrajong Avenue  
Mount Druitt  
Sydney  
NSW 2770  
Tel: 1300 304 320  
Fax: +61 (0) 2 9675 3390

**Ancon Building Products**  
4/15 Terrace Place  
Murarrie  
Brisbane  
QLD 4172  
Tel: 1300 304 320  
Fax: +61 (0) 7 3395 6693

**Ancon Building Products**  
7-9 Second Avenue  
Sunshine  
Melbourne  
VIC 3020  
Tel: 1300 304 320  
Fax: +61 (0) 3 9311 1777

**Ancon Building Products**  
18 Tennant Street  
Welshpool  
Perth  
WA 6105  
Tel: 1300 304 320  
Fax: +61 (0) 8 9453 2300

**NEW ZEALAND**

**Ancon Building Products**  
2/19 Nuttall Drive  
Hillsborough  
Christchurch 8022  
Tel: +64 (0) 3 376 5205  
Fax: +64 (0) 3 376 5206

Email: [info@ancon.com.au](mailto:info@ancon.com.au)  
Web: [www.ancon.com.au](http://www.ancon.com.au)  
International Enquiries: +61 (0) 2 8808 3100

**Overseas Offices:**

**Ancon Building Products**  
Sheffield  
United Kingdom  
[www.ancon.co.uk](http://www.ancon.co.uk)

**Ancon (Schweiz) AG**  
Ried bei Kerzers  
Switzerland  
[www.ancon.ch](http://www.ancon.ch)

**Ancon (Middle East) FZE**  
Dubai  
United Arab Emirates  
[www.ancon.ae](http://www.ancon.ae)

**Ancon Building Products GesmbH**  
Vienna  
Austria  
[www.ancon.at](http://www.ancon.at)

**Ancon GmbH**  
Nuremberg  
Germany  
[www.anconbp.de](http://www.anconbp.de)

These products are available from:

The construction applications and details provided in this literature are indicative only. In every case, project working details should be entrusted to appropriately qualified and experienced persons.

Whilst every care has been exercised in the preparation of this document to ensure that any advice, recommendations or information is accurate, no liability or responsibility of any kind is accepted in respect of Ancon Building Products.

With a policy of continuous product development Ancon Building Products reserves the right to modify product design and specification without due notice.

